

C. E. Dickson

R. W. "DICK" KINNEY
720 ASH ST.
BOWLING GREEN, OHIO

Cherokee

OWNER'S HANDBOOK

PIPER AIRCRAFT CORPORATION

the
PIPER
Cherokee

Owner's Handbook

Model B



Model PA-28-150, PA-28-160 & PA-28-180
PIPER AIRCRAFT CORPORATION
VERO BEACH, FLORIDA

Additional copies of this manual may be purchased by writing to the SERVICE DEPARTMENT, PIPER AIRCRAFT CORPORATION, Lock Haven, Pennsylvania, U.S.A.

SECTION II

DESIGN INFORMATION

Engine and Propeller	5
Structures	5
Landing Gear	6
Fuel System	7
Electrical System	8
Heating and Ventilating System	9
Cabin Features	9

SPECIFICATION FEATURES:

<u>POWER PLANT</u>	<u>PA-28-150</u>	<u>PA-28-160</u>	<u>PA-28-180</u>
Engine - Lycoming	*O-320-A2B	*O-320-B2B	O-360-A2A
Engine - Lycoming	**O-320-E2A	**O-320-D2A	
Rated Horsepower	150	160	180
Rated Speed RPM	2700	2700	2700
Bore, inches	5.125	5.125	5.125
Stroke, inches	3.875	3.875	4.375
Displacement (cubic inches)	319.8	319.8	361.0
Compression Ratio	7:1	8.5:1	8.5:1
Dry Weight, pounds	272	278	285
Fuel Consumption (75% power, gph)	9	9	10
Oil Sump Capacity (qts)	8	8	8
Fuel Aviation Grade Octane	80	91/96	91/96
Propeller (Sensenich)	M74DM58	M74DM60	M76EMM60

PERFORMANCE

Take-off Run, ft.	800	775	775
Best Rate of Climb Speed (MPH)	85	85	85
Rate of Climb (ft. per min.)	660	700	720
Service Ceiling (ft.)	14,300	15,000	15,700
Absolute Ceiling	16,800	17,500	18,300
Top Speed (MPH)	139 (142***)	141 (144***)	150
Cruising Speed (75% power, sea level MPH)	121 (124***)	123 (126***)	132

*This engine used in Cherokee with Serial Nos. 28-1 to 28-510

**This engine used in Cherokee with Serial Nos. 28-511 and up

***Wheel fenders optional equipment on PA-28-150 and -160

SPECIFICATION FEATURES: (cont)

<u>PERFORMANCE</u>	<u>PA-28-150</u>	<u>PA-28-160</u>	<u>PA-28-180</u>
Optimum Cruising Speed (75% power, 7000 ft., MPH)	130 (133***)	132 (135***)	141
Fuel Consumption (gal. per hr. 75%)	9	9	10
Cruising Range (75% power, sea level, std. fuel)	4 hrs. 490 mi.	4 hrs. 500 mi.	5 hrs. 660 mi.
Optimum Cruising Range (55% power, 10,000 ft. std. fuel,	5 hrs. 570 mi.	5 hrs. 580 mi.	7 hrs. 750 mi.
Cruising Range (75% power, sea level, reserve fuel)	5.5 hrs. 680 mi.	5.5 hrs. 695 mi.	
Optimum Cruising Range (55% power, 10,000 ft. reserve fuel 7.2 gph)	7 hrs. 790 mi.	7 hrs. 805 mi.	
Stalling Speed (flaps down, MPH)	54	55	57
Landing Roll (flaps down, ft.)	535	550	600

Performance figures are for standard airplanes flown at gross weight under standard conditions at sea level, or stated altitude. Any deviation from Standard equipment may result in changes in performance.

<u>WEIGHTS</u>	<u>PA-28-150</u>	<u>PA-28-160</u>	<u>PA-28-180</u>
Gross Weight (lbs)	2150	2200	2400
Empty Weight (Standard) (lbs)	1205	1210	1225

***Wheel fenders optional equipment on PA-28-150 and -160

SPECIFICATION FEATURES: (cont)

<u>WEIGHTS</u>	<u>PA-28-150</u>	<u>PA-28-160</u>	<u>PA-28-180</u>
<u>USEFUL LOAD</u>			
(Standard) (lbs)	945	990	1175
<u>Empty Weight</u>			
(AutoFlight) (lbs)	1245	1250	1265
<u>USEFUL LOAD</u>			
(AutoFlight) (lbs)	905	950	1135
<u>FUEL AND OIL</u>			
<u>Fuel Capacity</u>			
(Standard) (gal)	36	36	50
<u>Fuel Capacity (with reserve) (gal)</u>			
	50	50	
<u>Oil Capacity (qts)</u>			
	8	8	8
<u>BAGGAGE</u>			
Maximum Baggage (lbs)	100 (125*)	100 (125*)	125
Baggage Space (cubic ft)	19	19	19
Baggage Door Size (in)	20 x 22	20 x 22	20 x 22
<u>DIMENSIONS</u>			
Wing Span (ft)	30	30	30
Wing Area (sq. ft)	160	160	160
<u>Wing Loading (lbs. per sq. ft)</u>			
	13.4	13.8	15.0
Length (ft)	23.3	23.3	23.3
Height (ft)	7.3	7.3	7.3
<u>Power Loading (lbs. per HP)</u>			
	14.3	13.8	13.3
<u>LANDING GEAR</u>			
Wheel Base (ft)	6.2	6.2	6.2
Wheel Tread (ft)	10	10	10
<u>Tire Pressure (lbs)</u>			
Nose	18	18	18
Main	24	24	24

*PA-28 - Serial Nos. 28-725 and up

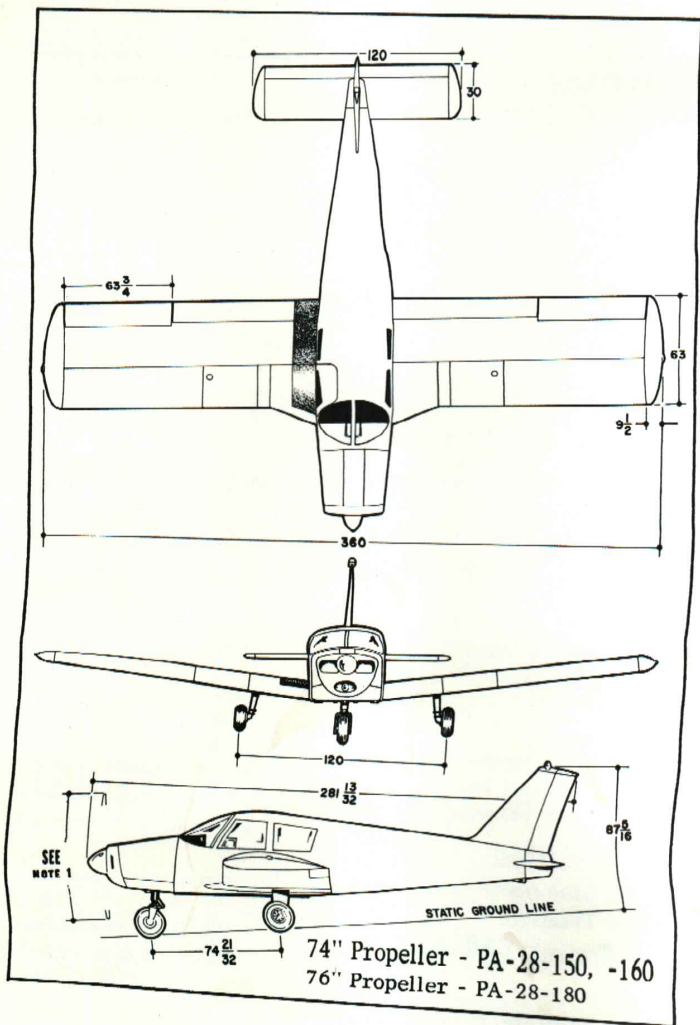

SECTION II

DESIGN INFORMATION

ENGINE AND PROPELLER

The Cherokee is powered by a Lycoming engine of either 150, 160 or 180 H.P. (Refer to Power Plant Specifications on Page 1) Each engine is furnished with a starter, 35 ampere 12 volt *generator or **alternator, voltage regulator, shielded ignition, vacuum pump drive, fuel pump and a dry, automotive type carburetor air filter.

The exhaust system is a stainless steel cross-over type. A large muffler with heater shroud is provided to supply heat for both the cabin and carburetor de-icing.

The propeller used is a Sensenich fixed pitch, all metal aluminum alloy. Refer to the Power Plant Specifications on Page 1 for the model of propeller used with each engine.

STRUCTURES

All structures are of aluminum alloy construction and are designed to ultimate load factors well in excess of normal requirements. All exterior surfaces are primed with etching primer and painted with acrylic enamel.

The wings are attached to each side of the fuselage by inserting the butt ends of the respective main spars into a spar box carry through which is an integral part of the fuselage structure, providing in effect a continuous main spar with splices at each side of the fuselage. There are also fore and aft attachments at the rear spar and at an auxiliary front spar.

The wing airfoil section is a laminar flow type, NACA 652-415 with the maximum thickness about 40% aft of the leading edge. This permits the main spar carry through structure to be located under the rear seat providing unobstructed cabin

*PA-28 Serial Nos. 28-1 to 28-507 inclusive

**PA-28 Serial Nos. 28-508 and up



floor space ahead of the rear seat.

LANDING GEAR

The three landing gears use a Cleveland 600 x 6 wheel, the main wheels being provided with brake drums and Cleveland single disc hydraulic brake assemblies, No. 30-18. All wheels use 600 x 6 four ply tires with tubes.

The nose gear is steerable through a 30 degree arc by use of the rudder pedals. A spring device is incorporated in the rudder pedal torque tube assembly to aid in rudder centering and to provide rudder trim. The nose gear steering mechanism also incorporates a hydraulic shimmy dampener.

The three struts are of the air-oil type, with the normal extension being 3-1/2 inches for the nose gear and 2 inches for the main gear.

The brakes are actuated by a hand lever and master cylinder, which is located below and behind the left center of the instrument sub-panel. The brake-fluid reservoir is installed

on the top, left, front face of the firewall. The parking brake is incorporated in the master cylinder and is actuated by pulling back on the brake lever and depressing the knob attached to the left side of the handle. Then release the brake lever. To release the parking brake, pull back on the brake lever to disengage the catch mechanism. Then allow the handle to swing forward.

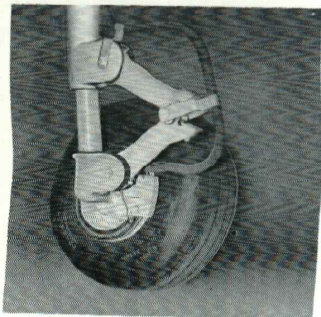

CONTROL SYSTEMS

Dual controls are provided as standard equipment, with a cable system used between the controls and the surfaces. The horizontal tail is of the all movable slab type, with an anti-servo tab which also acts as a longitudinal trim tab, actuated by a control on the cabin ceiling. The stabilator provides extra stability and controllability with less size, drag, and weight than conventional tail surfaces. The ailerons are provided with a differential action which tends to eliminate adverse yaw in turning maneuvers, and also reduces the amount of coordination required in normal turns.

The flaps are manually operated, balanced for light operating forces and spring loaded to return to the up position. A past-center lock incorporated in the actuating linkage holds the flap when it is in the up position so that it may be used as a step on the right side. The flap will not support a step load except when in the full up position, so it must be completely retracted when used as a step. The flaps have three extended positions, 10, 25 and 40 degrees.

FUEL SYSTEM

Fuel is stored in two twenty-five gallon tanks which are secured to the leading edge structure of each wing by screws and nut plates. This allows easy removal for service or inspection.

The standard quantity of fuel is 36 gallons for the Cherokee 150 and 160 and 50 gallons for the Cherokee 180. To obtain the standard quantity of 36 gallon of fuel on the 150 and 160 fill the tanks only to the bottom of the filler necks, which extends some distance into the tanks. To fill to the standard plus

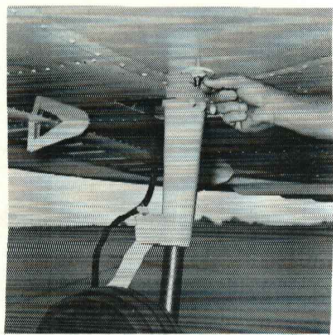

The fuel strainer, which is equipped with a quick drain, is located on the front lower left corner of the firewall. This strainer should be drained regularly to check for water or sediment accumulation. To drain the lines from the tanks, the tank selector valve must be switched to each tank in turn, with the electric pump on, and the gascolator drain valve opened. Each tank has an individual quick drain located at the bottom, inboard, rear corner.

Fuel quantity and pressure are indicated on gauges located in the engine gauge cluster on the right side of the instrument panel.

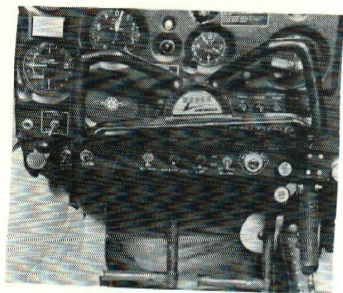

Electrical Switches

ELECTRICAL SYSTEM

The electrical system includes a 12 volt *generator or **alternator, battery, voltage regulator and master switch relay. The battery, regulator and relay are mounted in the battery compartment immediately aft of the baggage compartment. Access for service or inspection is conveniently obtained through a removable

*Generator installed on PA-28, Serial Nos. 28-1 to 28-507 inclusive

**Alternator installed on PA-28, Serial Nos. 28-508 and up

panel at lower right corner of the compartment.

Electrical switches, fuses and fuse spares are located on the lower left center of the instrument panel, and the left side of the instrument sub-panel.

Standard electrical accessories include: Starter, Electric Fuel Pump, Fuel Gauge, Stall Warning Indicator, Cigar Lighter and Ammeter.

Navigation Lights, Anti-Collision Light, Landing Light, Instrument Lighting and the Cabin Dome Light are offered as optional accessories.

Circuit provisions are made to handle optional communications and navigational equipment.

Installed on late model Cherokees (Serial Nos. 28-508 and up) is the Piper F.T.P. (Full Time Power) Electrical System.

Derived from this system are many advantages both in operation and maintenance. The main advantage is, of course, full electrical power output regardless of engine R.P.M. This is a great improvement for radio and electrical equipment operation. Also because of the availability of generator output at all times, the battery will be charging for a greater percentage of use, which will greatly improve cold-morning starting.

Unlike previous generator systems, the ammeter does not indicate battery discharge, rather it displays the load in amperes placed on the system. With all electrical equipment off (except master switch) the ammeter will be indicating the amount of charging current demanded by the battery. This amount will vary, depending on the percentage of full charge in the battery at the time. As the battery becomes charged, the amount of current displayed on the ammeter will reduce to about two amperes. When each piece of electrical equipment is switched on, the currents will add up and the total, including the battery, will appear on the ammeter. The maximum continuous load for night flight, with radios on, is about 30 amperes. This 30-ampere value, plus approximately two amperes for a fully charged battery, will appear continuously under these flight conditions.

The amount of current shown on the ammeter will tell immediately whether or not the generator system is operating normally as this amount of current shown should equal the total amount of amperes being drawn by the equipment which is operating.

Maintenance on the alternator will prove to be a minor factor. Should service be required, contact the local Piper Dealer.

HEATING AND VENTILATING SYSTEM

Heat for the cabin interior and the defroster system is provided by a heater muff attached to the exhaust system. The amount of heat desired can be regulated with the controls located on the lower right side of the instrument panel.

A control is provided to regulate the amount of fresh air to the cabin interior. Also provided are side vents at each seat location. These vents are regulated as desired by the seat occupant.

CABIN FEATURES

The instrument panel of the Cherokee is designed to accommodate the customary advanced flight instruments and all the normally required power plant instruments. The Artificial Horizon, Directional Gyro and the Turn and Bank instruments are vacuum operated through use of a vacuum pump installed on the engine. A natural separation of the flight group and the power group is provided by placing the communications and radio navigational equipment in the center of the panel.

The front seats are adjustable fore and aft for pilot comfort and ease of entry and exit.

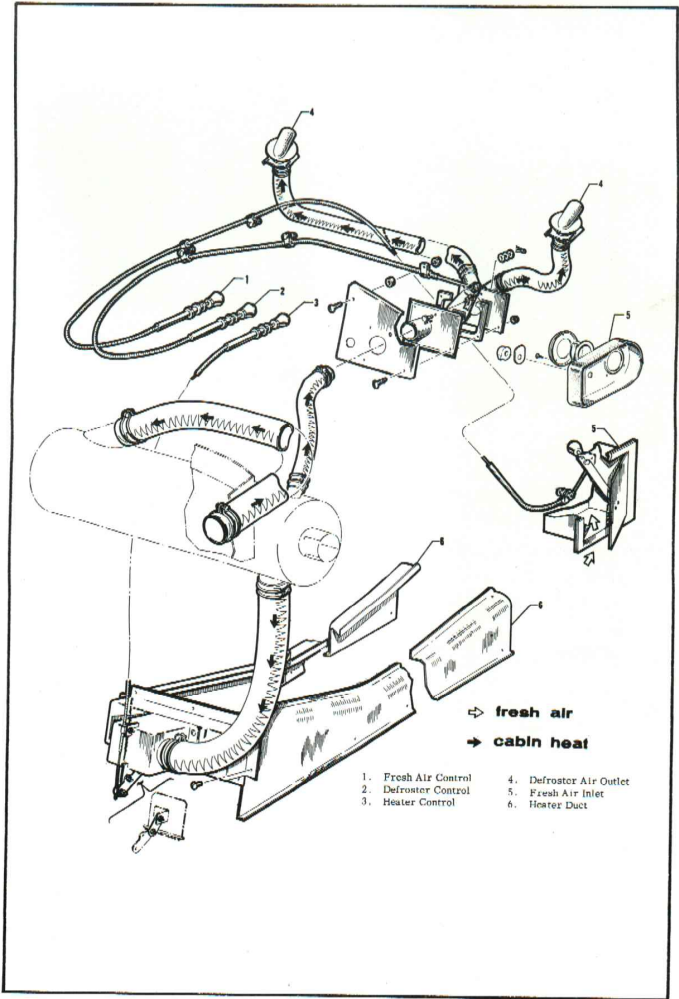

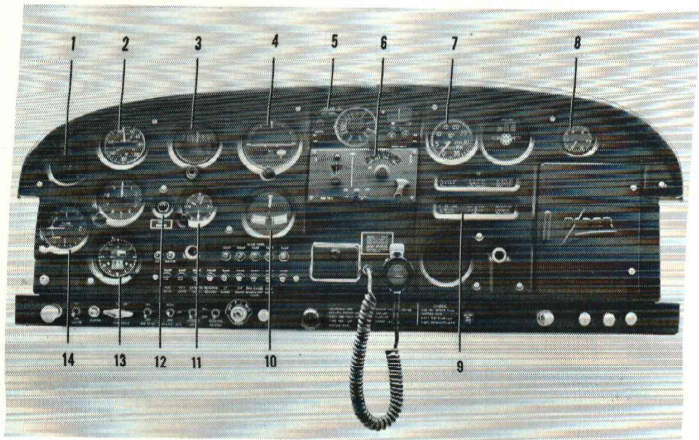

- | | |
|-------------------------------|-----------------------------|
| 1. Compass | 8. Vacuum Gauge |
| 2. Airspeed Indicator | 9. Instrument Cluster |
| 3. Directional Gyro Indicator | 10. Turn and Bank Indicator |
| 4. Gyro Horizon Indicator | 11. Clock |
| 5. AutoNav Radio | 12. Stall Warning Light |
| 6. Piper PTR-I Radio | 13. Omni Indicator |
| 7. Tachometer | 14. Rate of Climb Indicator |

SECTION III
OPERATING INSTRUCTIONS

Preflight	13
Starting	14
Warm-up	15
Ground Check	16
Take-off	16
Climb	17
Stalls	17
Cruising	17
Approach and Landing	18
Ground Handling and Mooring	19
Weight and Balance	19

SECTION III

OPERATING INSTRUCTIONS

PREFLIGHT

The airplane should be given a thorough visual inspection prior to each flight. Particular attention should be given to the following items:

1. a. Ignition and battery switches "OFF".
2. a. There is no external damage or operational interference to the control surfaces, wings or fuselage.
b. There is no snow, ice, or frost on the wings or control surfaces.
3. a. Check fuel supply visually, and insure that caps are secure.
b. Drain the fuel tank sumps.
c. Check to insure the fuel system vents are open.

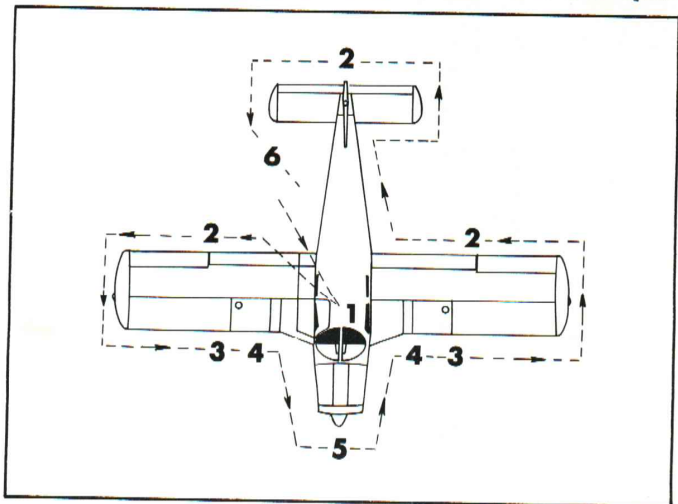

4. a. The landing gear shock struts are properly inflated. (Refer to Section V)
- b. The tires are satisfactorily inflated and not excessively worn.
5. a. The cowlings and inspection covers are secured.
- b. The windshield is clean and free of defects.
- c. The propeller is free of detrimental nicks.
- d. There are no obvious fuel or oil leaks.
- e. The engine oil is at the proper level.
- f. Drain the fuel strainer.
6. a. The tow-bar and control locks are detached and properly stowed.
7. a. Upon entering the airplane, ascertain that all controls operate properly.
- b. Close and secure the cabin door.
- c. Check that required papers are in order and in the airplane.

STARTING

After completion of the preflight inspection:

1. Lock the wheel brakes.
2. Set the carburetor heat control in the full "COLD" position.
3. Select the desired tank with the fuel valve.
4. Move the mixture to the full "RICH" position.
5. Open the throttle $1/8$ to $1/4$ inch.
6. Turn the electric fuel pump "ON".

In cold weather (below 40 degrees F.) prime the engine with one to three full strokes of the priming pump. If extremely cold, starting will be aided by pulling the propeller through by hand (switch "OFF") four to five revolutions. If the temperature is above 40 degrees the engine may be primed by three or four short quick strokes of the throttle.

After priming, turn the electric master switch on, engage the starter and allow the engine to turn approximately one full revolution, then turn the ignition switch to the "Left" magneto

position.

When the engine is firing evenly, turn the magneto switch to the "Both" position and advance the throttle to 800 RPM. Check the oil pressure gauge for a pressure indication. If oil pressure is not indicated within thirty seconds, stop the engine and determine the trouble.

If the engine fails to start at the first attempt, another attempt should be made without priming. If this fails, it is possible that the engine is overprimed. Turn the magneto switch off, open the throttle slowly, and rotate the engine approximately ten revolutions with the starter. Reprime the engine with one half the amount used in the initial attempt, turn the magneto switch to "Left", and repeat the starting procedure. If the engine again fails to start, refer to the "Lycoming Operating Handbook, "Section VII, "Engine Troubles".

WARM-UP

The engine on the Cherokee is air pressure cooled and depends on the forward speed of the airplane to provide an adequate air flow for proper cooling. Therefore, particular care is necessary when operating the engine on the ground. To prevent overheating and possible damage to the engine, it is recommended that the following precautions be observed:

1. Head the airplane into the wind.
2. Avoid prolonged idling at low RPM's, as this practice may result in fouled spark plugs.
3. Limit ground running time to four minutes in cold weather (below 70 degrees), and to two minutes in warm weather.

The engine is warm enough for take-off when the throttle may be opened fully without engine backfiring or skipping. If electrical power is desired during the warm-up to prevent battery drain, the engine may be idled slightly over 1200 RPM, which is the generator cut-in RPM.

GROUND CHECK

With the engine running at 1800 RPM, switch from both magnetos to only one and note the RPM loss, switch to the other magneto and again note the RPM loss. Drop off on either magneto should not exceed 125 RPM.

Check both the oil temperature and pressure. The temperature may be low for some time if the engine is being run for the first time of the day, but as long as the pressure is within limits the engine is ready for take-off.

Carburetor heat should also be checked prior to take-off to be sure that the control is operating properly, and to clear any ice which may have formed during taxiing.

TAKE-OFF

Just before take-off the following items should be checked:

1. Controls free
2. Flaps "UP"
3. Tab set
4. Mixture "RICH"
5. Carburetor heat "OFF"
6. Fuel on proper tank
7. Electric fuel pump "ON"
8. Engine gauges normal
9. Door latched
10. Altimeter set

The take-off technique is conventional for the Cherokee. The tab should be set slightly aft of neutral, with the exact setting determined by the loading of the aircraft. Allow the airplane to accelerate to 50 to 60 miles per hour, then ease back on the wheel enough to let the airplane fly itself off the ground. Premature raising of the nose, or raising it to an excessive angle will result in a delayed take-off. After take-off let the aircraft accelerate to the desired climb speed by lowering the nose slightly.

CLIMB

The best rate of climb at gross weight will be obtained at 85 miles per hour. The best angle of climb may be obtained at 74 miles per hour. At lighter than gross weight these speeds are reduced somewhat. For climbing enroute a speed of 100 miles per hour is recommended. This will produce better forward speed and increased visibility over the nose during the climb.

STALLS

The gross weight stalling speed of the Cherokee with power off and full flaps is 54 MPH on the 150, 55 MPH on the 160 and 57 MPH on the Cherokee 180. This speed is increased 9 miles per hour with the flaps up.

CRUISING

The cruising speed of the Cherokee is determined by many factors including power setting, altitude, temperature, loading, and equipment installed on the airplane.

The normal cruising power is 75% of the rated horsepower of the engine. True airspeeds which may be obtained at various altitudes and power settings can be determined from the charts in "Section IV" of this handbook.

Use of the mixture control in cruising flight reduces fuel consumption significantly, especially at high altitudes. The mixture should always be leaned during cruising operations at 75% power or less, but during the climb only at altitudes above 5000 feet.

The continuous use of carburetor heat during cruising flight decreases engine efficiency. Unless icing conditions in the carburetor are severe, do not cruise with the heat on. Apply full carburetor heat slowly and only for a few seconds at intervals determined by icing severity.

In order to keep the airplane in best lateral trim during cruising flight the fuel should be used alternately from each tank. It is recommended that one tank should be used for one

hour after take-off, then the other tank used for two hours, then return to the first tank, which will have approximately one and one half hour of fuel remaining if the tanks were full plus reserve at take-off. The second tank will contain approximately one half hour of fuel.

APPROACH AND LANDING

The airplane should be trimmed to an approach speed of about 85 miles per hour, and flaps extended. The flaps can be lowered at speeds up to 115 miles per hour if desired. Carburetor heat should not be applied unless there is an indication of carburetor icing, since the use of carburetor heat causes a reduction in power which may be critical in case of a go-around. Full throttle operation with heat on is likely to cause detonation.

The amount of flap used during landings and the speed of the aircraft at contact with the runway should be varied according to the landing surface, and existing conditions both windwise, and loadwise. It is generally good practice to contact the ground at the minimum possible safe speed consistent with existing conditions.

Normally the best technique for short and slow landings is to use full flap and enough power to maintain the desired airspeed and approach flight path. Mixture should be full rich, fuel on the fullest tank, carburetor heat off, and electric fuel pump on. Reduce the speed during the flareout and contact the ground close to the stalling speed (50 to 60 MPH). After ground contact hold the nose wheel off, as long as possible. As the airplane slows down, drop the nose and apply the brakes. There will be less chance of skidding the tires if the flaps are retracted before applying the brakes. Braking is most effective when back pressure is applied to the control wheel, putting most of the aircraft weight on the main wheels. In high wind conditions, particularly in strong cross winds, it may be desirable to approach the ground at higher than normal speeds, with partial or no flaps.

GROUND HANDLING AND MOORING

The Cherokee should be moved on the ground with the aid of the nose wheel tow bar provided with each plane and secured in the baggage compartment. Tie downs may be secured to rings provided under each wing, and to the tail skid. The aileron and stabilator controls should be secured by looping the safety belt through the control wheel, and pulling it tight. The rudder is held in position by its connections to the nose wheel steering, and normally does not have to be secured. The flaps are locked when in the full up position, and should be left retracted.



WEIGHT AND BALANCE

For weight and balance data, see the Airplane Flight Manual, and Weight and Balance form supplied with each airplane. This form gives the exact weight of each individual airplane as manufactured and the permissible center of gravity conditions.

SECTION IV

PERFORMANCE CHARTS

Take-off Distance vs Standard Altitude . . .	21
Rate of Climb vs Standard Altitude	22
True Airspeed and RPM vs Standard Altitude .	23
Range vs Standard Altitude	24
Landing Distance vs Standard Altitude	25
True Airspeed and RPM vs Standard Altitude, PA-28-180	26
Range vs Standard Altitude, PA-28-180	26a

PIPER CHEROKEE PA-28-150-160-180

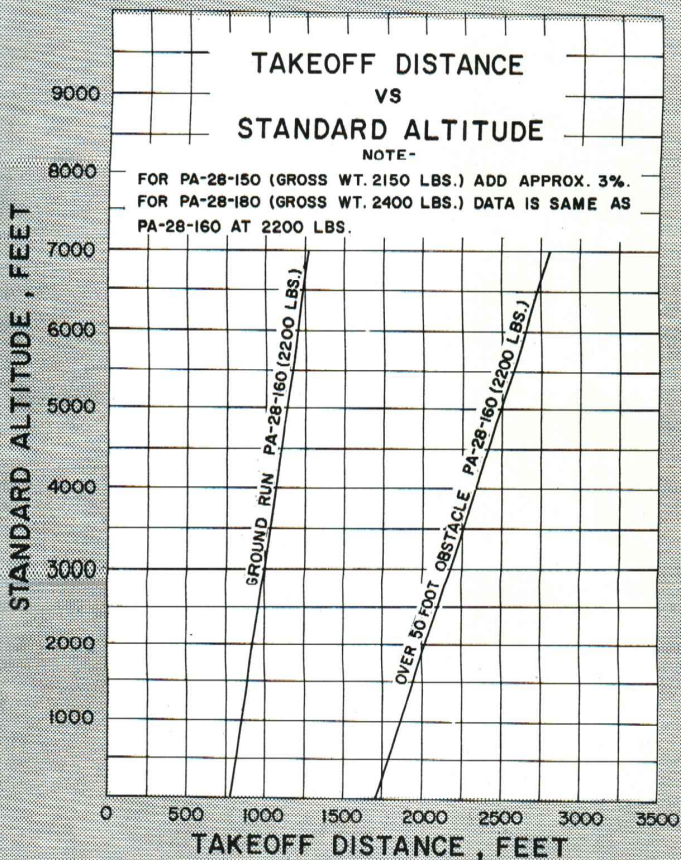

PIPER CHEROKEE

PA-28-150-160-180

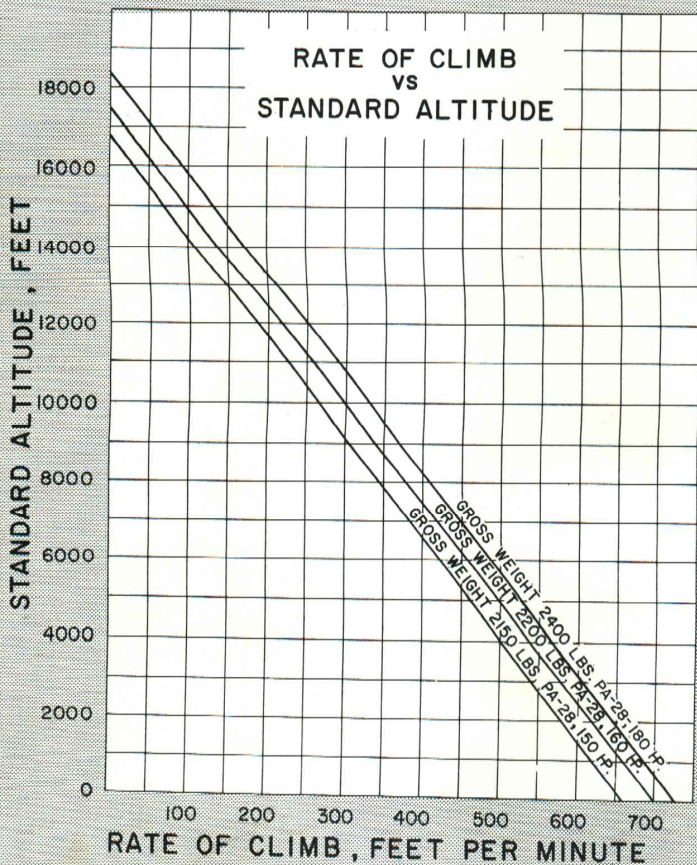

PIPER CHEROKEE PA-28-160

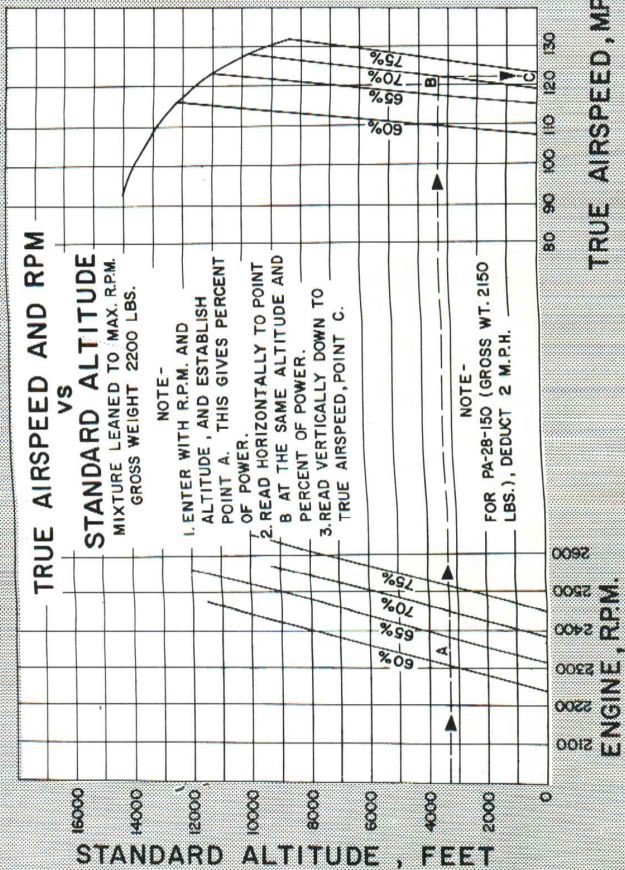

PIPER CHEROKEE

PA-28-160

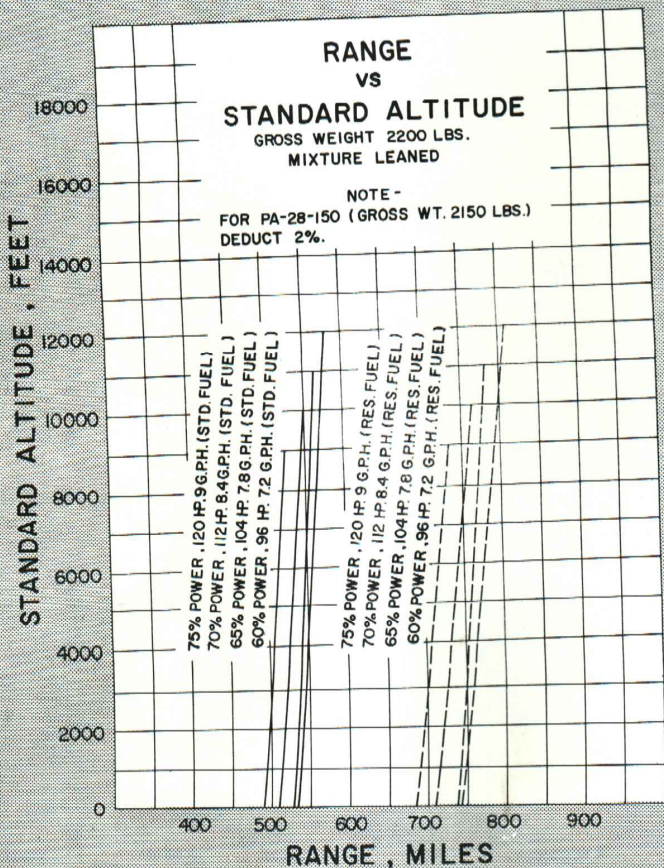

PIPER CHEROKEE PA-28-150-160-180

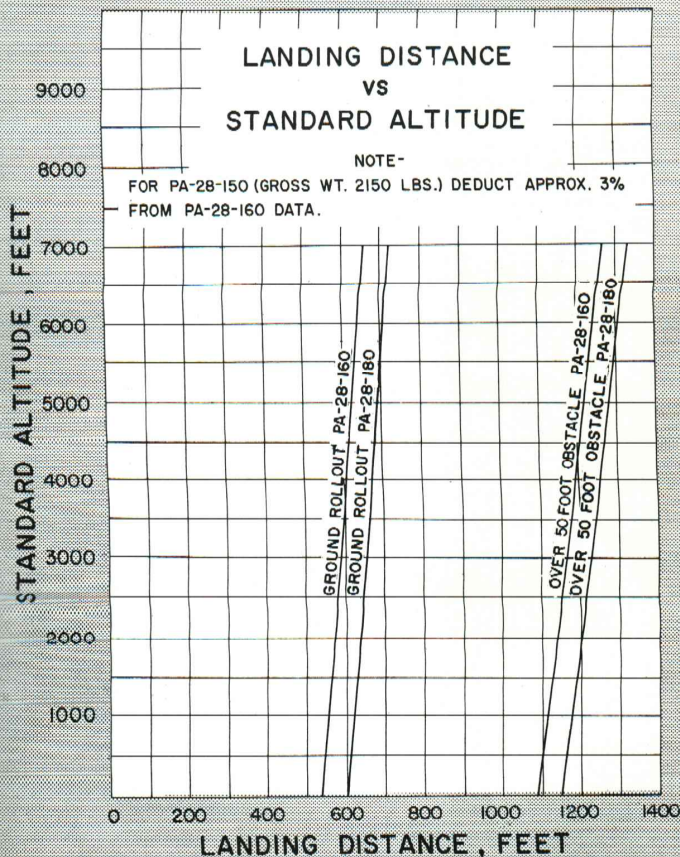

PIPER CHEROKEE

PA-28-180

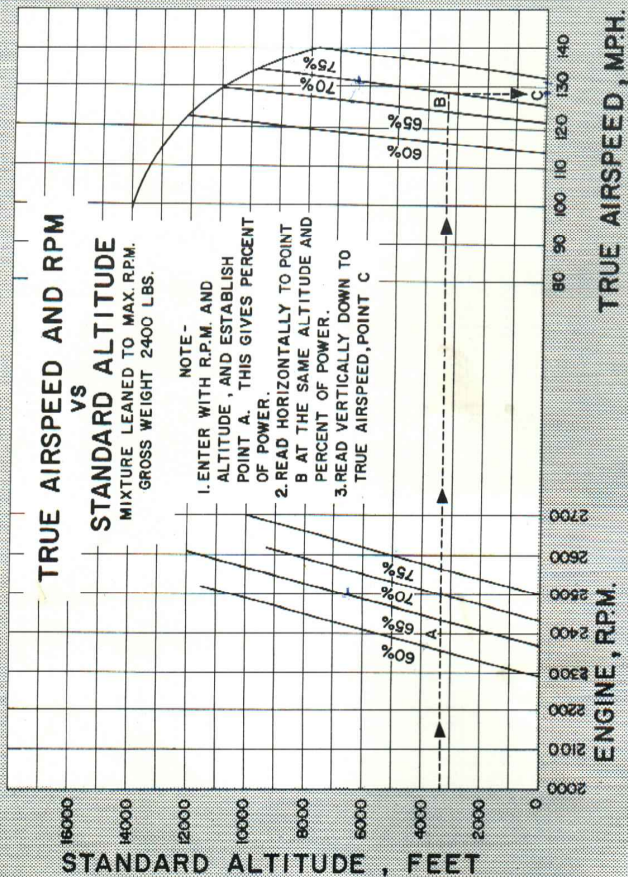

PIPER CHEROKEE PA-28-180

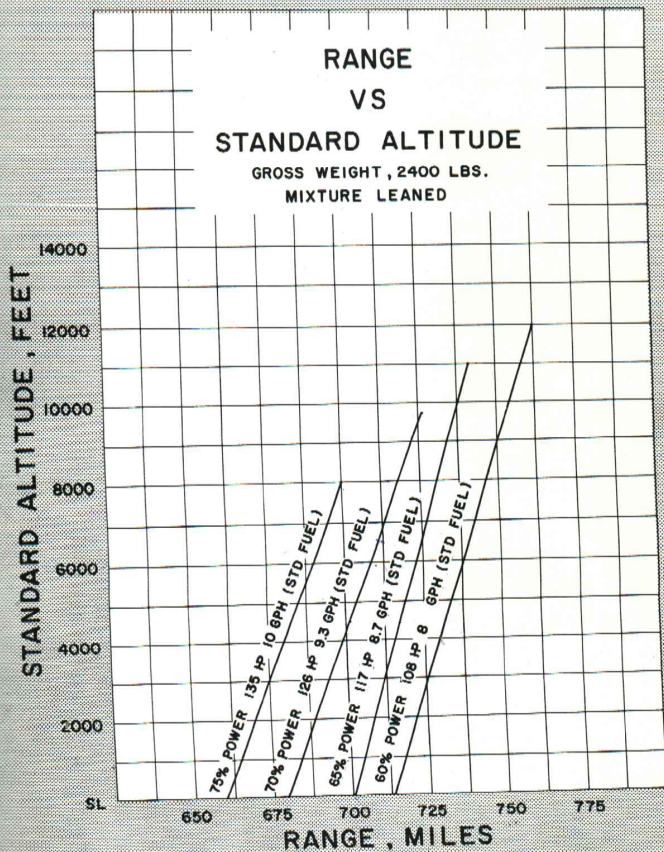

SECTION V

GENERAL MAINTENANCE

Tire Inflation	27
Battery Service	27
Brake Service	27
Landing Gear Service	28
Fuel and Oil Requirements	30
Care of Air Filter	30
Care of Windshield and Windows	30
Serial Number Plate	31
Leveling and Rigging	31

SECTION V

GENERAL MAINTENANCE

TIRE INFLATION

For maximum service from the tires on the Cherokee, keep the tires inflated to the proper pressure of 24 pounds for the main gear, and 18 pounds for the nose wheel. Interchange the tires on the main wheels if necessary to produce even wear. All wheels and tires are balanced before original installation, and the relationship of the tire, tube and wheel should be maintained if at all possible. Out of balance wheels can cause extreme vibration on take-off. In the installation of new components, it may be necessary to rebalance the wheel with the tires mounted.

BATTERY SERVICE

Access to the 12 volt battery is through the right rear baggage compartment panel. The stainless steel box has a plastic drain tube which is normally closed off with a clamp and which should be opened occasionally to drain off any accumulation of liquid. The battery should be checked for proper fluid level, but must not be filled above the baffle plates. A hydrometer check should be performed to determine the percent of charge present in the battery.

If the battery is not up to charge, recharge starting at a 4 amp rate and finishing with a 2 amp rate. Quick charges are not recommended.

BRAKE SERVICE

The brake system is filled with Unavis No. 40 (petroleum base) hydraulic brake fluid. This should be checked at every 100 hour inspection and replenished when necessary by filling the brake reservoir on the firewall to the indicated level. If the system as a whole has to be refilled with fluid, this should

be done by filling with the fluid under pressure, from the brake end of the system. This will eliminate air from the system as it is being filled.

No adjustment of brake clearances is necessary on the Cherokee brakes. If after extended service the brake blocks become worn excessively, they are easily replaced with new segments.

LANDING GEAR SERVICE

Main wheels are easily removed by taking off the hub cap, axle nut, and the two bolts holding the brake segment in place, after which the wheel slips easily from the axle.

Tires are demounted from the wheels by first deflating the tire, then removing the three through bolts, and separating the wheel halves.

Landing gear oleos on the Cherokee should be serviced according to the instructions on the units. In order to obtain the correct static extension on the main gear struts it is necessary to jack the airplane up until the struts are clear of the ground and fully extended. Using a strut pump, add air until a pressure of 150 pounds is obtained. To add oil to the struts, release the air pressure in the strut, remove the valve core and add oil through this opening with the strut fully extended. After the strut is full compress it to full compression allowing excess air and oil to escape. With the strut still compressed reinsert the valve stem and pump up the strut as above. The nose strut is serviced with oil the same as the main struts, but in filling with air this strut may be left with the wheel on the ground, attaching the strut pump, and adding air until a strut extension of 3-1/2 inches is obtained.

In jacking the Cherokee for landing gear or other service, a jack kit (available through the Piper Aircraft Service Department) should be used. This kit consists of two hydraulic jacks and a tail stand. At least 250 pounds of ballast should be placed on the base of the tail stand before jacking up the aircraft. The hydraulic jacks should be placed under the jack points on the bottom of the wing and the airplane jacked up until the tail

**Cherokee Fuel System
PA-28-150, PA-28-160 & PA-28-180**

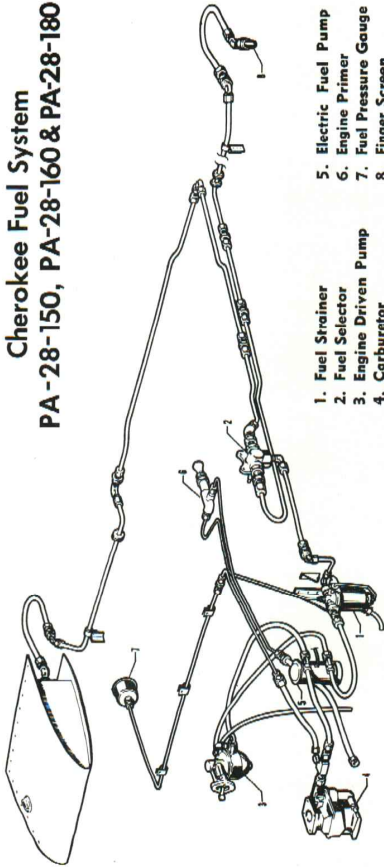

- | | |
|-----------------------|------------------------|
| 1. Fuel Strainer | 5. Electric Fuel Pump |
| 2. Fuel Selector | 6. Engine Primer |
| 3. Engine Driven Pump | 7. Fuel Pressure Gauge |
| 4. Carburetor | 8. Finger Screen |

skid is at the right height to attach the tail stand. After attaching the tail stand, and adding the ballast, the jacking may be continued until the aircraft is at the height desired.

FUEL AND OIL REQUIREMENTS

Aviation grade 80 Octane (minimum) fuel must be used in the Cherokee 150 while the Cherokee 160 and 180 will utilize 91 Octane fuel. The use of lower grades can cause serious engine damage in a very short period of time, and is considered of such importance that the engine warranty is invalidated by such use.

The oil capacity of the Lycoming O-320 series and O-360 is 8 quarts, and the minimum safe quantity is 2 quarts. It is recommended that the oil be changed every 50 hours, or sooner under unfavorable conditions. The following grades are recommended for the specified temperatures:

Temperatures above 40 ⁰ F	S.A.E. 50
Temperatures between 10 ⁰ and 40 ⁰ F	S.A.E. 30
Temperatures below 10 ⁰ F	S.A.E. 20

CARE OF AIR FILTER

The carburetor air filter must be cleaned at least once every fifty hours. Under extremely adverse conditions of operation it may be necessary to clean the filter daily. Extra filters are inexpensive and a spare should be kept on hand and used as a rapid replacement.

The following cleaning procedure is recommended by the filter manufacturer:

1. Remove the air-filter landing-light assembly.
2. Remove filter and tap gently to remove dirt particles. Do not blow out with compressed air.
3. Reinstall filter and replace the air-filter landing-light assembly.

CARE OF WINDSHIELD AND WINDOWS

A certain amount of care is needed to keep the plexiglas

windows clean and unmarred. The following procedure is recommended:

1. Flush with clean water and dislodge excess dirt, mud, etc., with your hand.
2. Wash with mild soap and water. Use a soft cloth or sponge, do not rub.
3. Remove oil, grease or sealing compounds with a soft cloth and kerosene.
4. After cleaning, apply a thin coat of hard polishing wax. Rub lightly with a soft cloth.
5. A severe scratch or mar may be removed by using jeweler's rouge to rub out the scratch, smoothing, and then applying wax.

SERIAL NUMBER PLATE

The serial number plate is located near the stabilator on the left side of the airplane. Refer to this number for service or warranty matters.

LEVELING AND RIGGING

Leveling the Cherokee for purposes of weighing or rigging is accomplished as follows:

1. Partially withdraw two machine screws located immediately below the left front side window. These screws are leveling points and the airplane is longitudinally level when a level placed on the heads of these screws indicates level.
 2. To put the airplane in a longitudinally level position on scales, first block the main gear oleos in the fully extended position, then deflate the nose wheel tire until the proper attitude is obtained. For rigging only, the airplane may be placed on jacks for leveling.
 3. To level the airplane laterally, place a level across the baggage compartment floor along the rear bulkhead.
- Rigging: Although the fixed flight surfaces on the Cherokee cannot be adjusted for rigging purposes, it may be necessary upon occasion to check the position of these surfaces. The